

n ≈ 1450 rpm

پمپ WKL4 , WKL 4 125

تیپ پمپ	توان P		آمپر A	قطر پروانه D (mm)	قطر فلنج mm		Q آبدھی								
	KW	HP			مکش	رانس	m ³ /h	100	150	175	200	225	250	275	300
							l/s	27.8	41.7	48.6	55.6	62.5	69.5	76.4	83.4
WKL4 125.1 E	22	30	43.5	285	150	125	H (m)	28.5	26	24	22	19.5	17	*	*
WKL4 125.1 D	30	40	58	295				31	28.3	26.7	24.7	22.4	19.5	*	*
WKL4 125.1 C	30	40	58	300				33	30.7	29	27	24.8	22.2	19.5	*
WKL4 125.1 B	30	40	58	310				35.7	33	31.4	29.5	27.3	25	22.5	19.5
WKL4 125.1 A	37	50	71	320				38.4	35.6	33.8	32	29.7	27.5	25	22.5
WKL4 125.2 E	45	60	87	285				57	51.9	48.3	44	39.3	34	*	*
WKL4 125.2 D	55	75	104	295				61.5	56.8	53.4	49.2	44.8	39	*	*
WKL4 125.2 C	55	75	104	300				66	61.3	58	54	49.6	44.4	38	*
WKL4 125.2 B	55	75	104	310				71	66	62.8	59	54.6	50	45	39
WKL4 125.2 A	75	100	142	320				76	71	67.8	64	59.5	55	50	45
WKL4 125.3 E	75	100	142	285				85.5	78	72.3	66	58.5	51	*	*
WKL4 125.3 D	75	100	142	295				92.8	85.4	80	73.8	67.2	58.5	*	*
WKL4 125.3 C	75	100	142	300				99.2	92.3	87.2	81.3	74.4	66.6	57	*
WKL4 125.3 B	90	125	168	310				107	99.2	94.2	88.5	82	75	67.5	58.5
WKL4 125.3 A	90	125	168	320				114	106.4	101.4	96	89.2	82.5	75	67.5
WKL4 125.4 E	90	125	168	285				113	103.6	96.6	88	78	68	*	*
WKL4 125.4 D	110	150	205	295				123	113.8	106.8	98.4	89.4	78	*	*
WKL4 125.4 C	110	150	205	300				132	123	116.4	108.4	99.2	88.8	76	*
WKL4 125.4 B	110	150	205	310				142	132	125.6	118	109.2	100	90	78
WKL4 125.4 A	132	180	245	320				152	142	135.6	128	119.2	110.2	100.2	90

H	m	17	23	30	40	49	61	76	92	107	122	137	152
	ft	55	75	100	130	160	200	250	300	350	400	450	500

Q	m ³ /h	100	150	175	200	225	250	275	300
	g.p.m	380	568	662	757	850	945	1040	1135

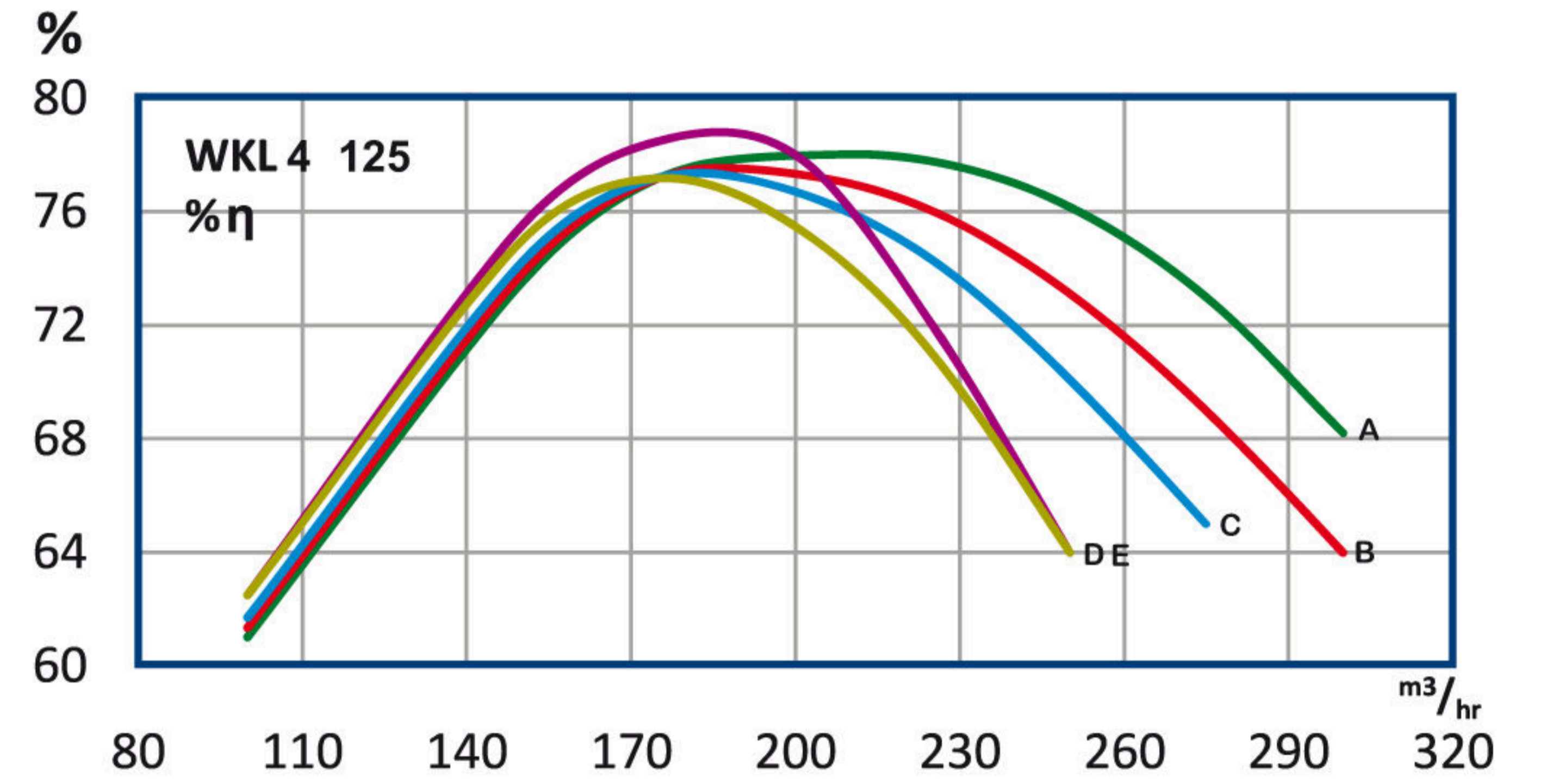
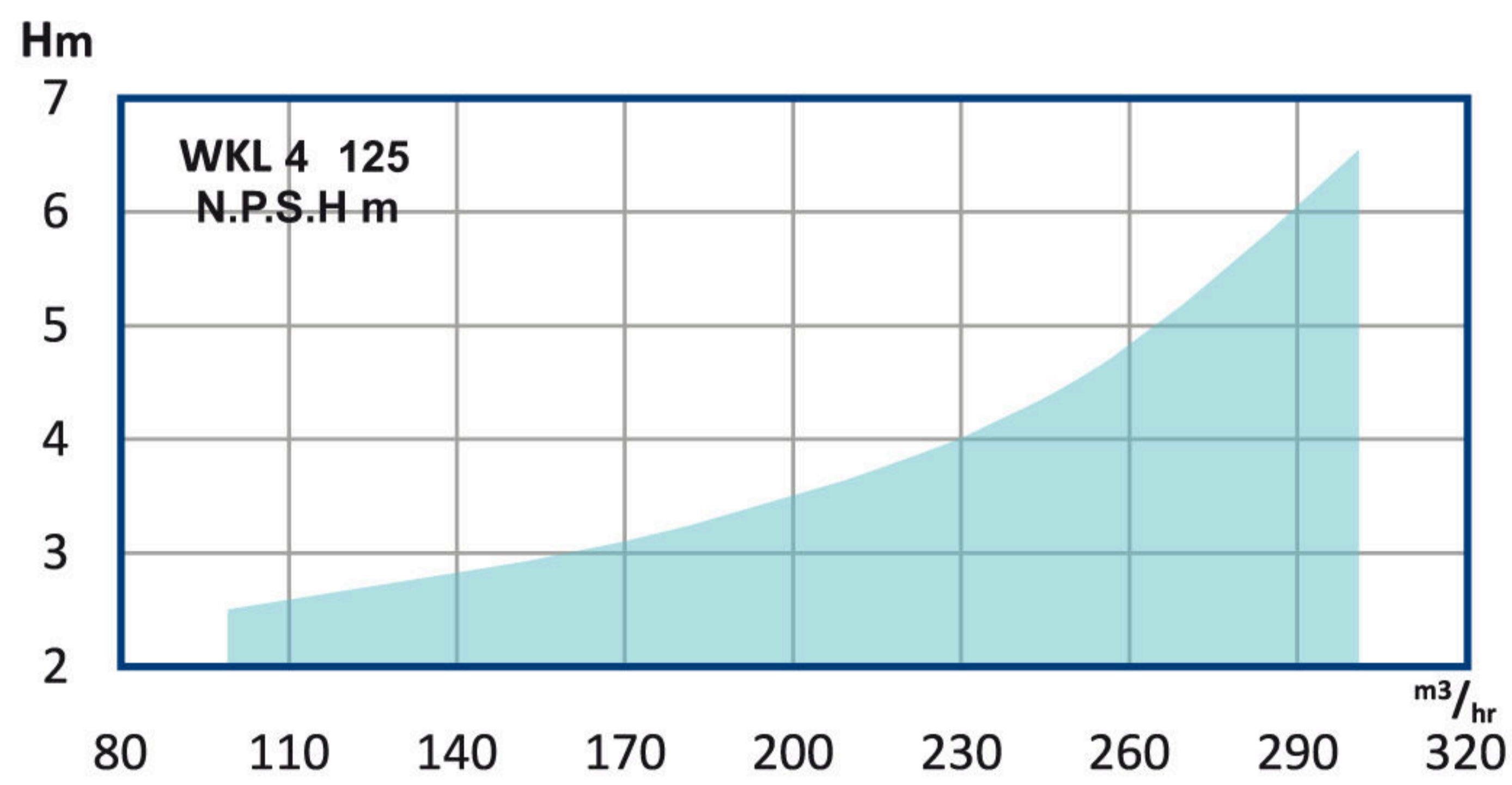
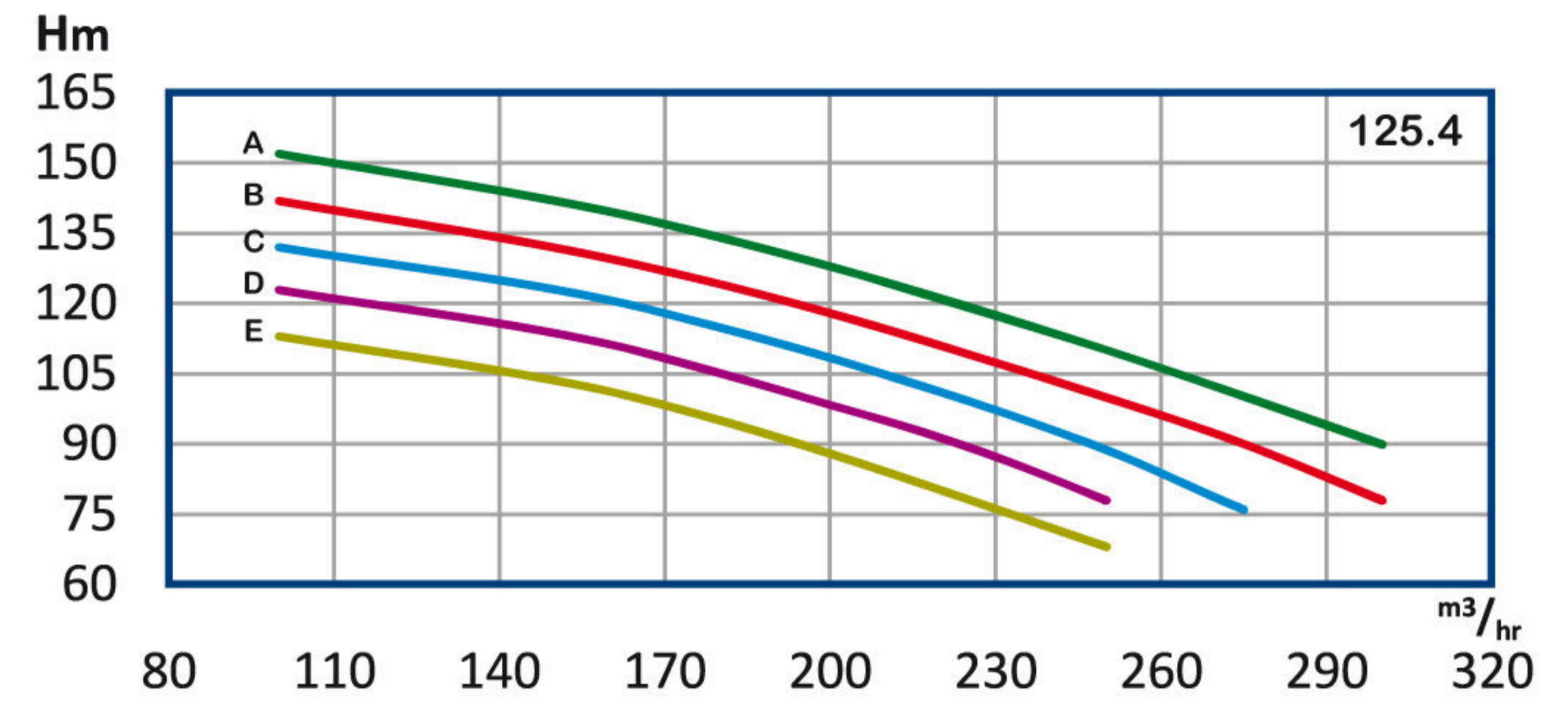
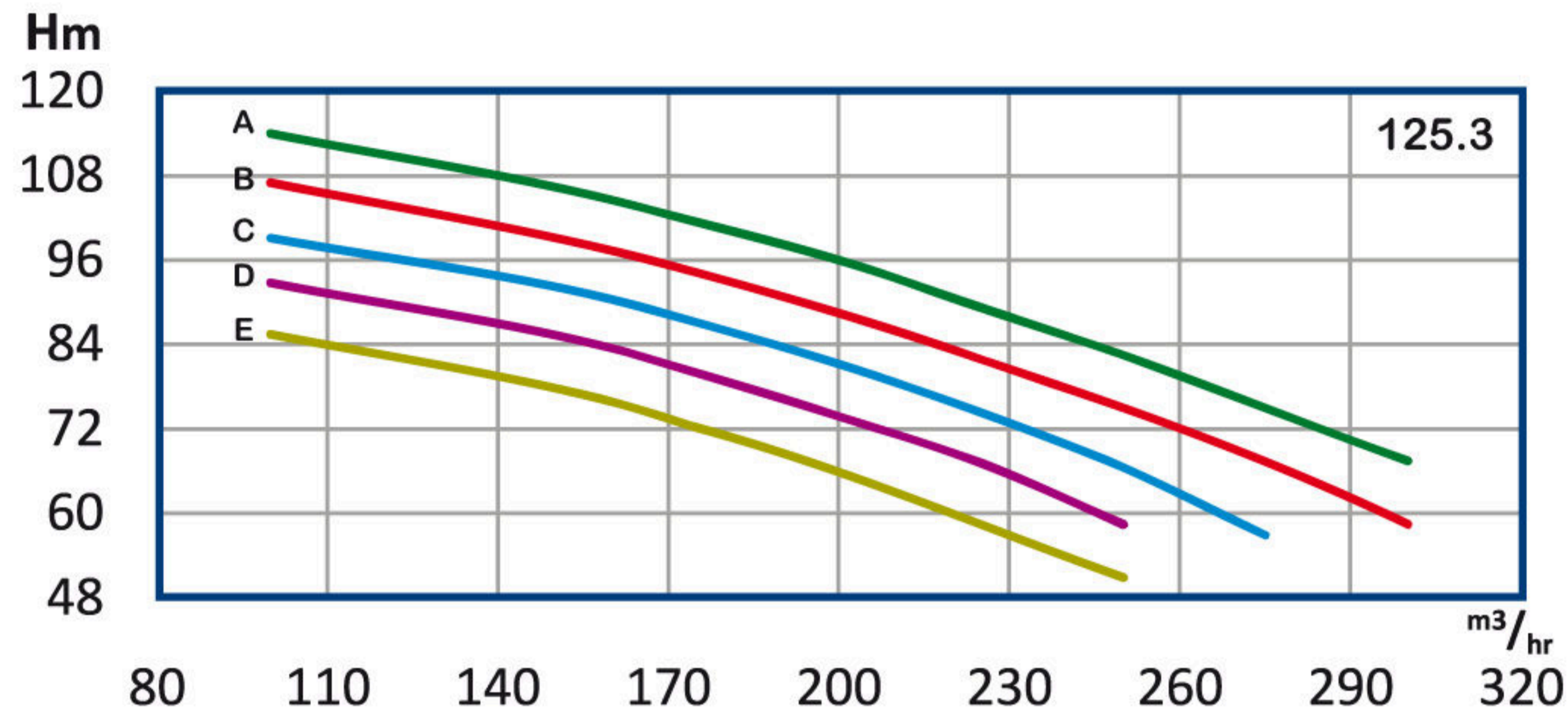
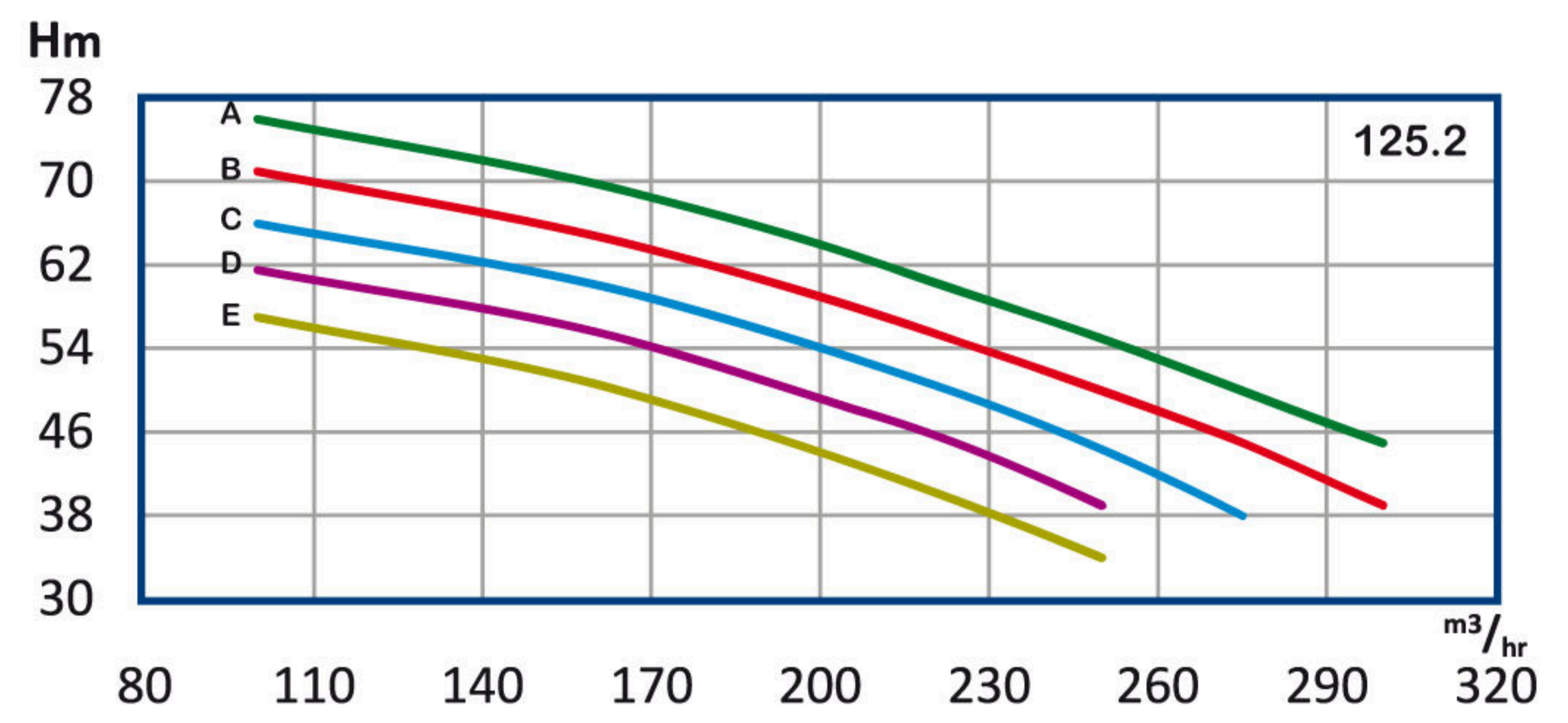
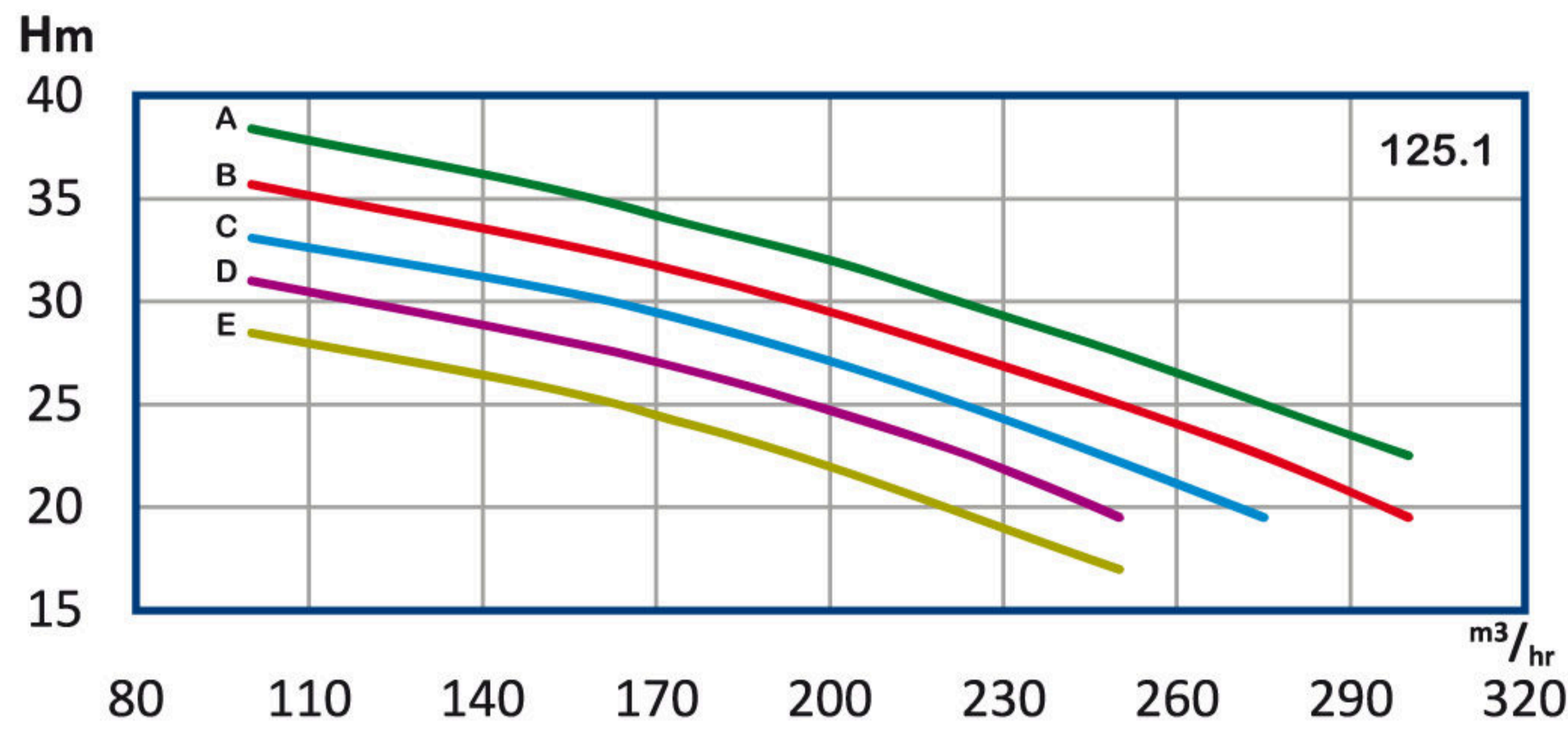

n ≈ 1450 rpm

پمپ WKLV4, WKL 4 125

تیپ پمپ	توان P		آمپر A	قطر پروانه D (mm)	قطر فلنج mm		Q آبدھی								
	KW	HP			مکش	رانس	m ³ /h	100	150	175	200	225	250	275	300
							l/s	27.8	41.7	48.6	55.6	62.5	69.5	76.4	83.4
WKLV4 125.5 E	110	150	205	285	150	125	H (m)	142.5	129	120.5	110	97.5	85	*	*
WKLV4 125.5 D	132	180	245	295				155	142	133.5	123	112	97.5	*	*
WKLV4 125.5 C	132	180	245	300				165.5	153.8	145.4	135.3	123.8	110.8	95	*
WKLV4 125.5 B	160	220	295	310				178.5	166	157	147.5	136.3	124.7	112	97
WKLV4 125.5 A	160	220	295	320				192	178	169	160	148.8	137.5	125	112
WKLV4 125.6 E	132	180	245	285				171	156	144.6	132	117	102	*	*
WKLV4 125.6 D	160	220	295	295				185	171	160.4	147.7	134	117	*	*
WKLV4 125.6 C	160	220	295	300				198.6	184	174	162.5	148.7	133	114	*
WKLV4 125.6 B	160	220	295	310				214	198.6	188.4	177	163.8	150	135	117
WKLV4 125.6 A	200	270	360	320				229	213	203	192	178.5	165	150	135
WKLV4 125.7 E	132	180	245	285				199	182	168.5	154	136.5	119	*	*
WKLV4 125.7 D	160	220	295	295				216	199.6	186.8	172.5	156.6	136	*	*
WKLV4 125.7 C	200	270	360	300				231.5	215.4	203.4	189.5	173.6	155.4	133	*
WKLV4 125.7 B	200	270	360	310				250	231.8	219.8	206.5	191	175	157.5	136.5
WKLV4 125.7 A	200	270	360	320				268	249.2	237	224	208.3	192.5	175	157.5

H	m	85	100	116	131	146	162	180	199	216	235	253	275
	ft	280	330	380	430	480	530	590	650	710	770	830	900

Q	m ³ /h	100	150	175	200	225	250	275	300
	g.p.m	380	568	662	757	850	945	1040	1135

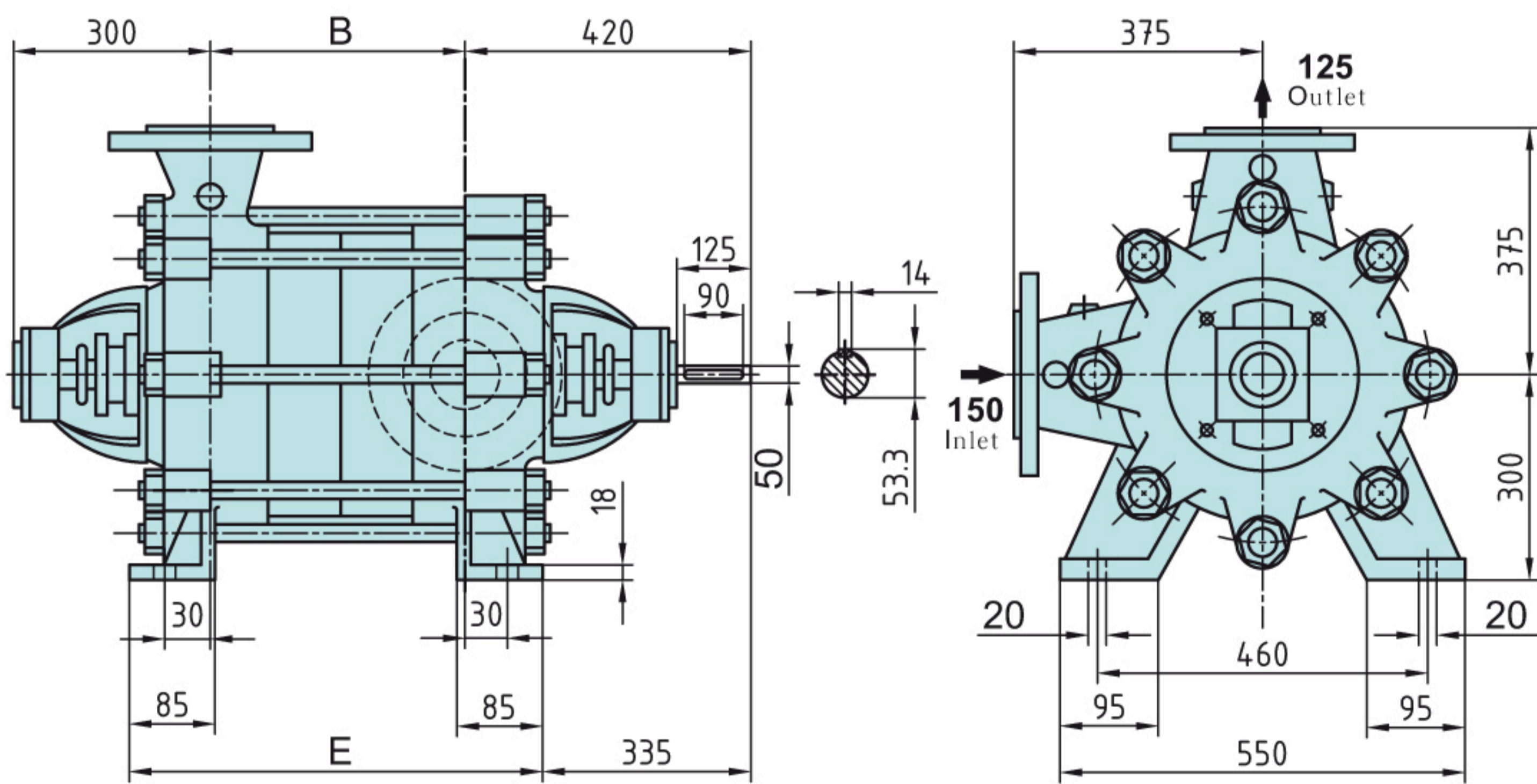
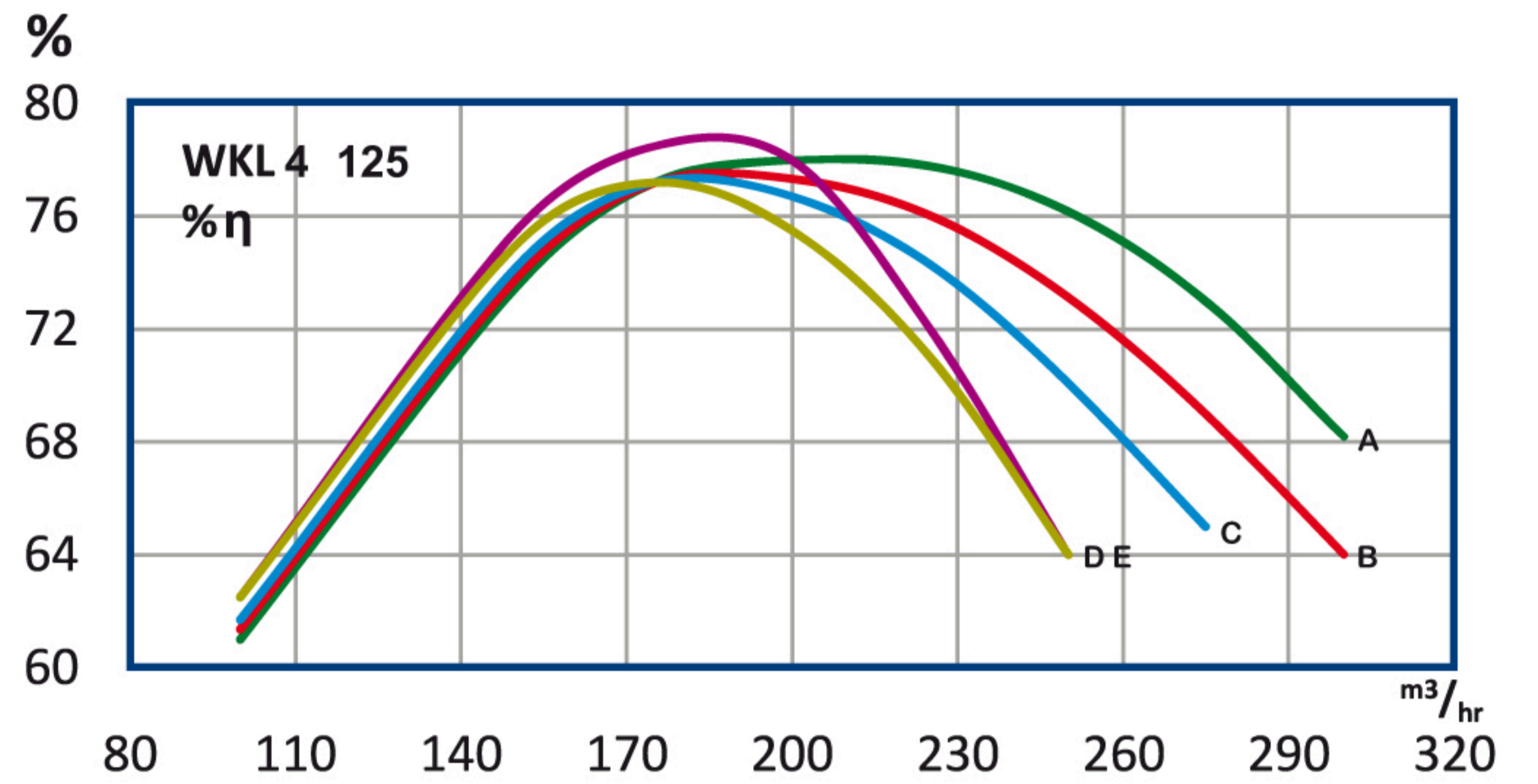
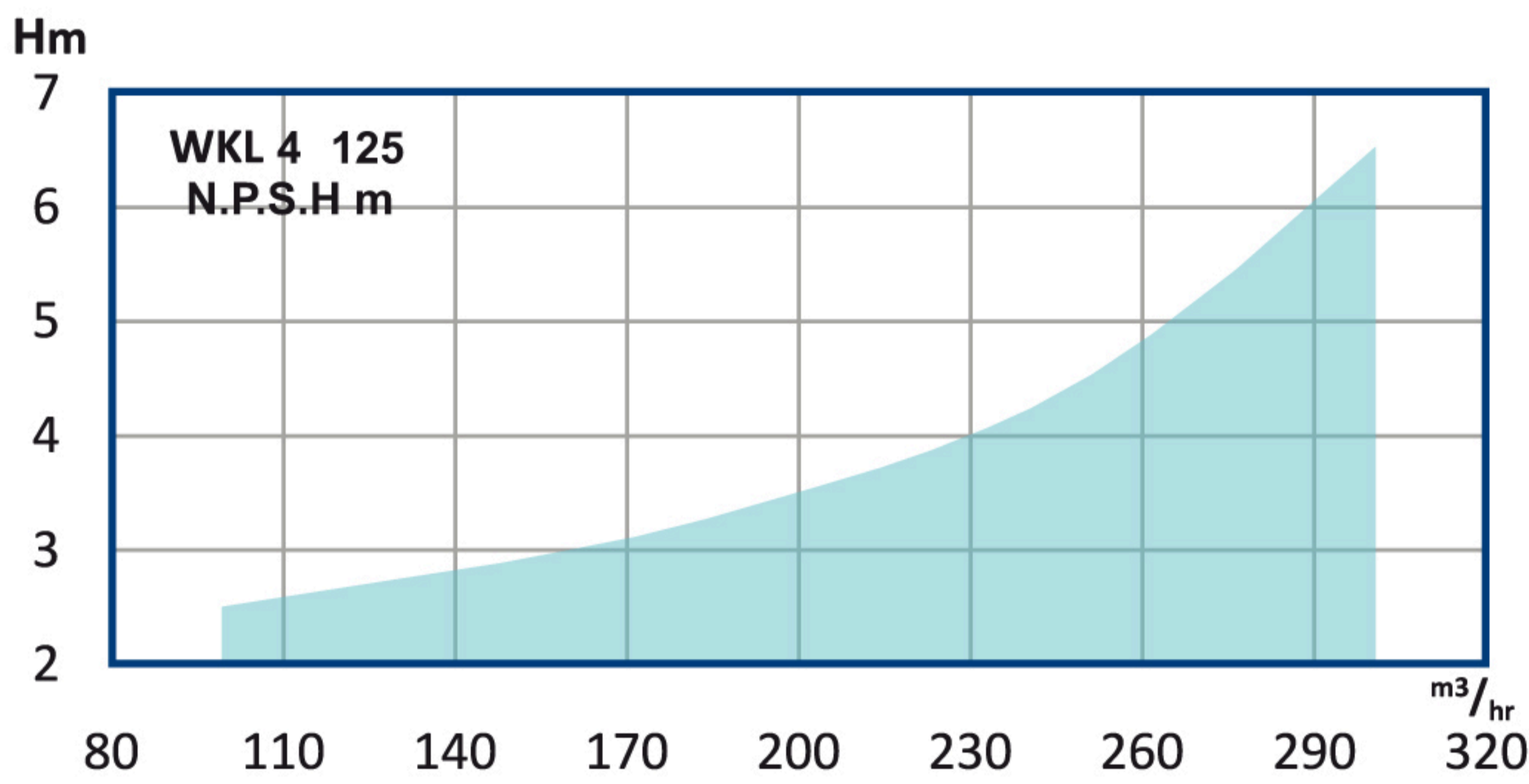
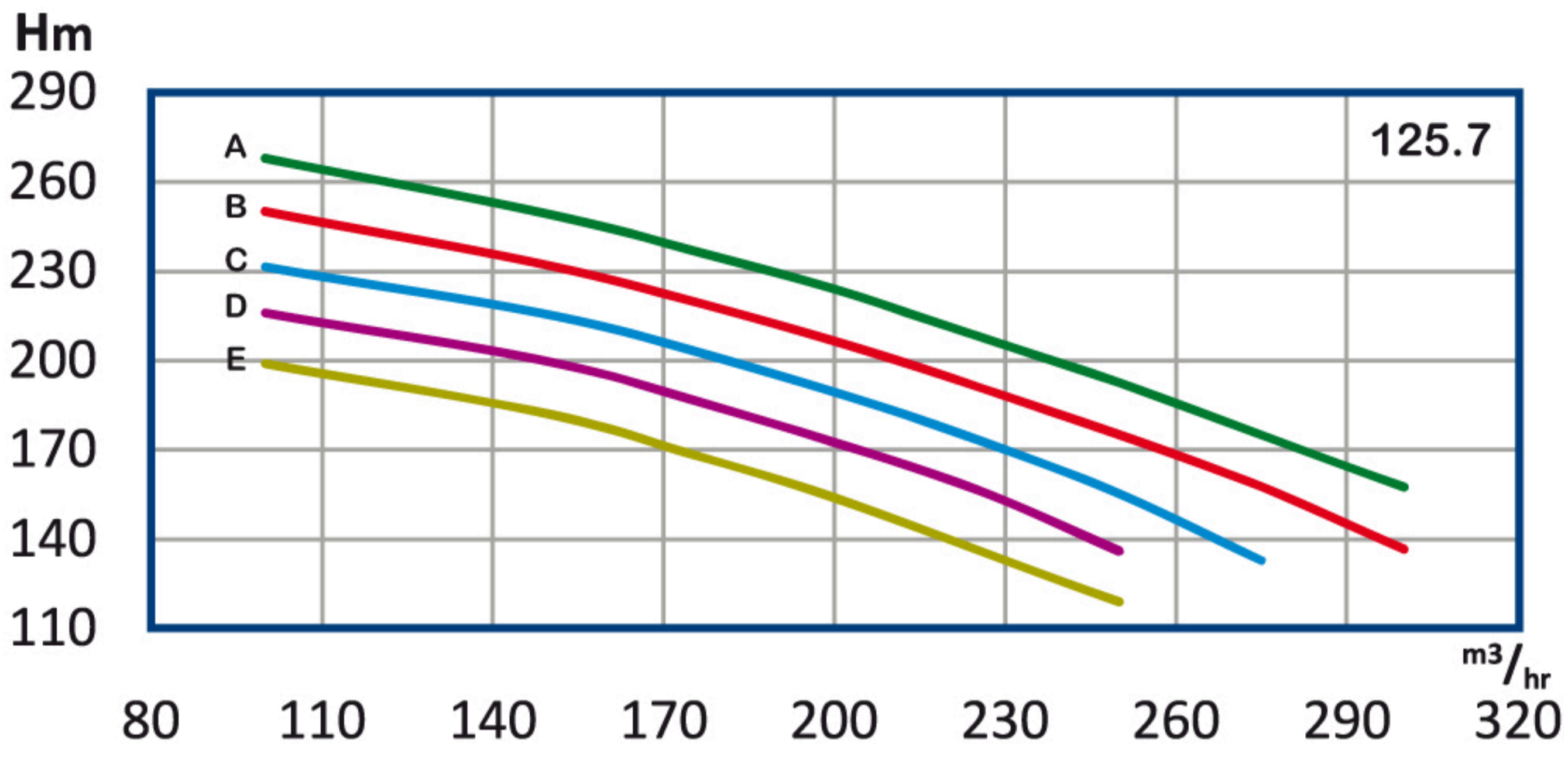
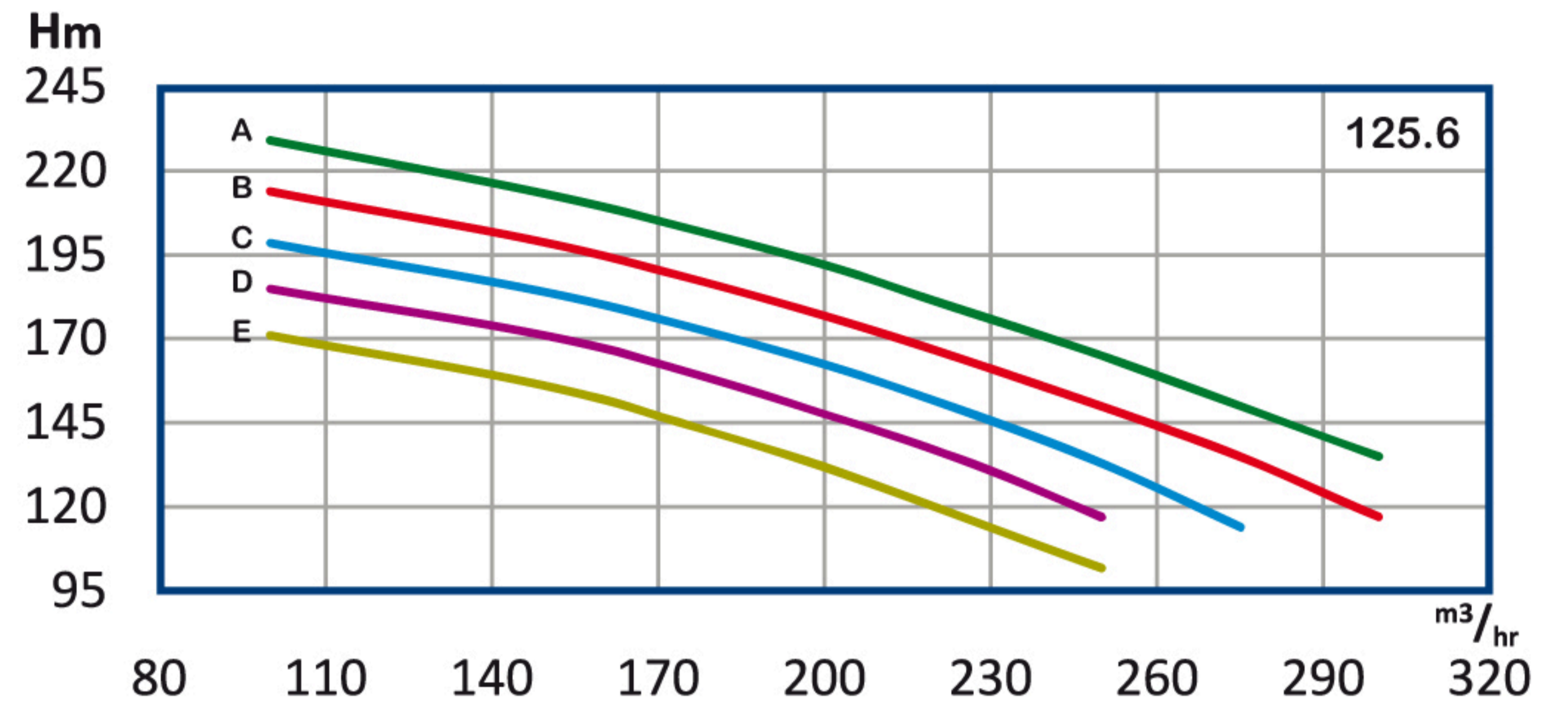
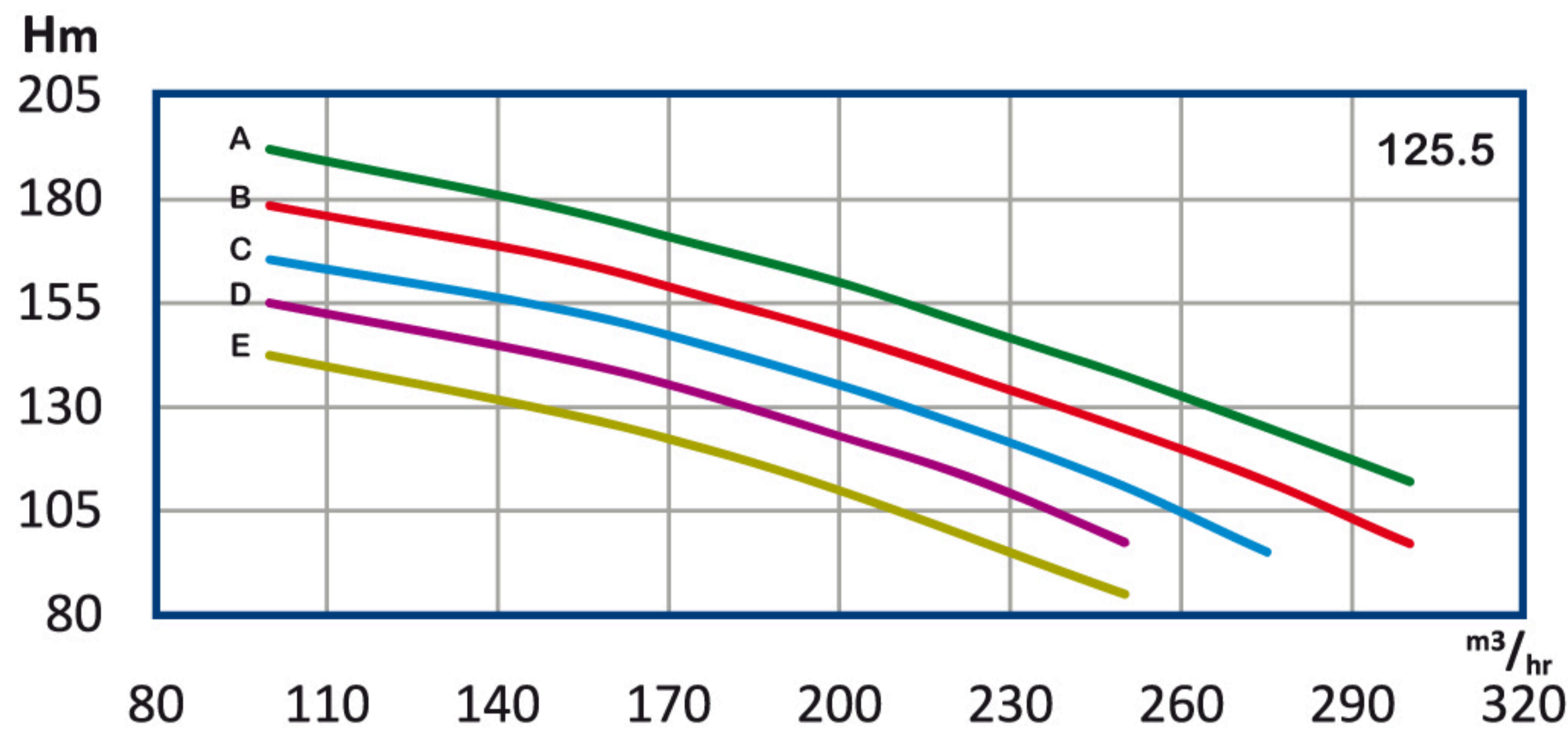

جدول طول پمپ WKL4 125 (mm)

تعداد طبقه	B	E	تعداد طبقه	B	E
1	165	335	5	625	795
2	280	450	6	740	910
3	395	565	7	855	1015
4	510	680			

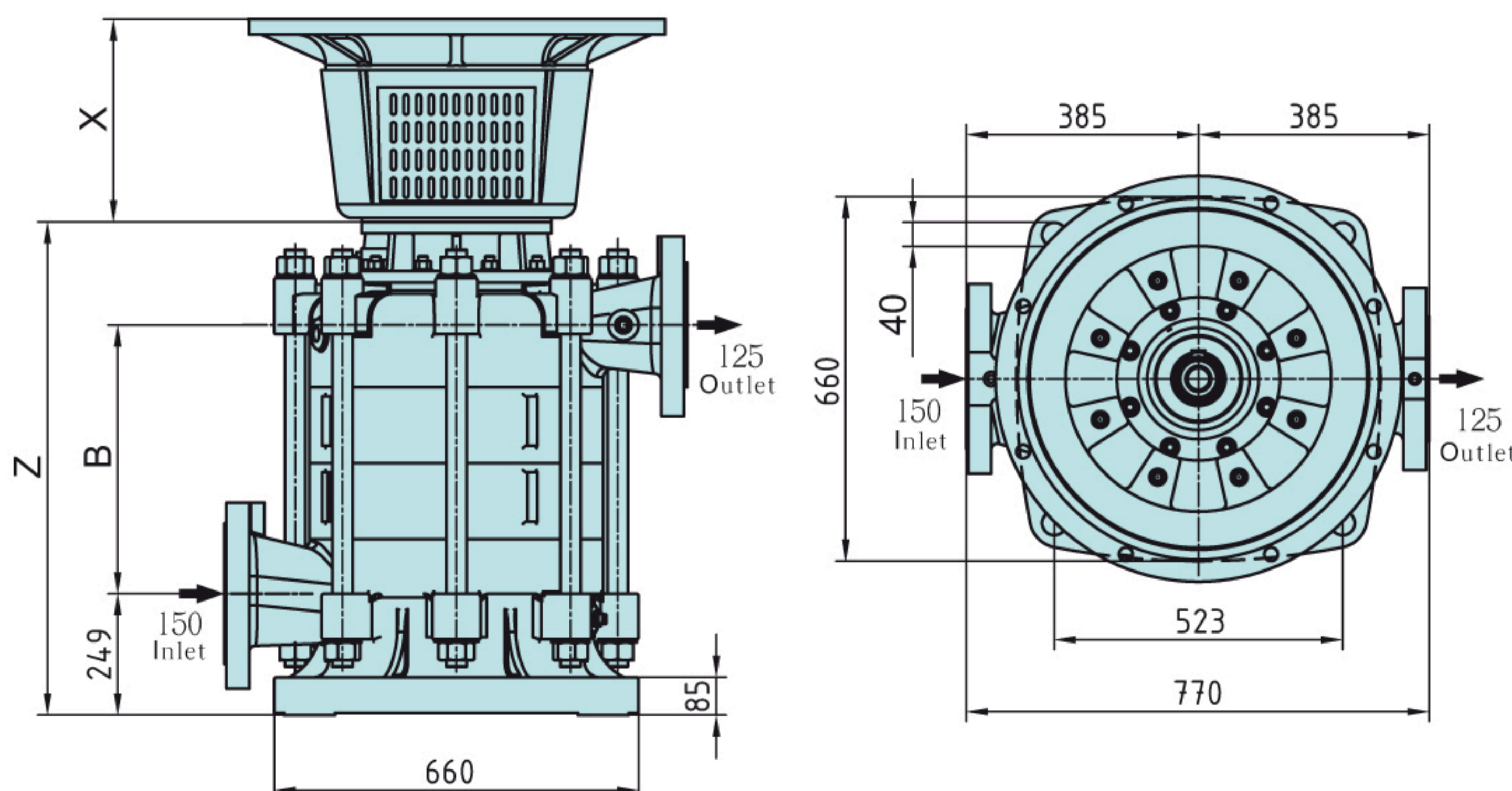

جدول طول پمپ WKL4 125 (mm)

تعداد طبقه	B	Z	تعداد طبقه	B	Z
1	172	641	5	632	1101
2	287	756	6	747	1216
3	402	871	7	862	1331
4	517	986			

X: متناسب با قدرت الکترو موتور تغییر می یابد.

جدول ابعاد پمپ های WKLV4 , WKLV (80-150)

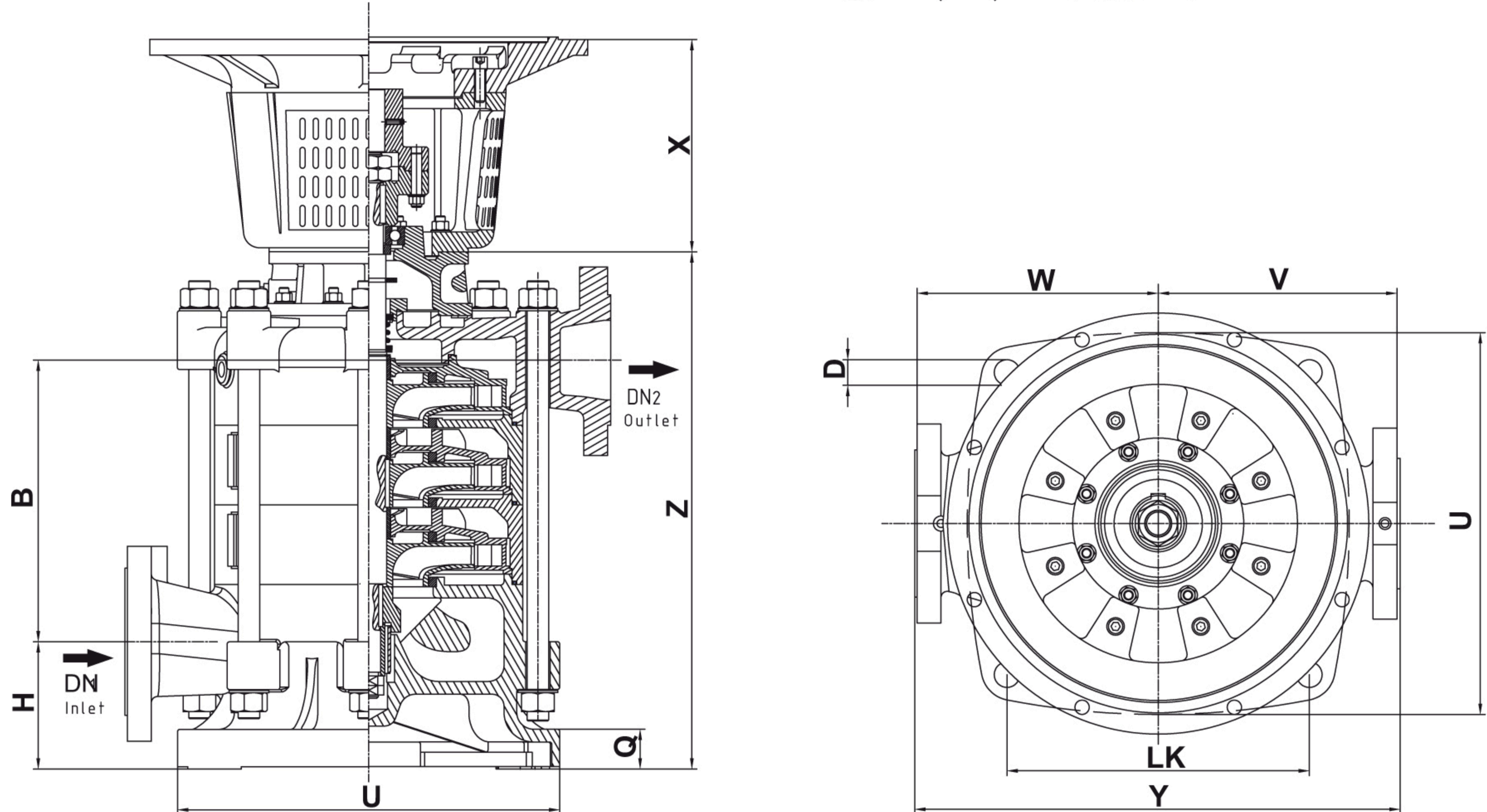

Type	(mm)									
	DN1	DN2	LK	Y	U	D	W	V	Q	H
WKLV4 / WKLV 80	100	80	324	526	400	24	260	260	45	162
WKLV4 100	125	100	380	610	480	32	303	300	50	160
WKLV4 125	150	125	523	769	660	40	385	384	85	249
WKLV4 150	200	150	545	865	685	40	430	435	85	276

Type	طول پمپ	(mm)											
		1	2	3	4	5	6	7	8	9	10	11	12
WKLV4 / WKLV 80	B	95	178	261	344	427	510	593	676	759	842	925	1009
	Z	401	484	567	650	733	816	899	982	1065	1148	1231	1314
WKLV4 100	B	154	254	354	454	554	654	754	854	954	1054	*	*
	Z	450	550	650	750	850	950	1050	1150	1250	1350	*	*
WKLV4 125	B	172	287	402	517	632	747	*	*	*	*	*	*
	Z	631	746	861	976	1091	1206	*	*	*	*	*	*
WKLV4 150 Type A	B	214	359	504	649	794	939	*	*	*	*	*	*
	Z	750	895	1040	1185	1330	1475	*	*	*	*	*	*
WKLV4 150 Type B	B	214	359	504	649	794	939	*	*	*	*	*	*
	Z	730	875	1020	1165	1310	1455	*	*	*	*	*	*